

# Market Day! Tote

“Bound to Please” in the Spring 2010 issue of Quick Quilts Magazine



Web Bonus pattern for tote  
by Cate Tallman-Evans

From the Fruit collection by Michael Miller Fabrics,  
[www.michaelmillerfabrics.com](http://www.michaelmillerfabrics.com)

Bag Sizes: Large: 20" wide x 16" high; Small: 16" wide x 16" high

## Materials You Will Need:

- 1-5/8 yards of black pear/apple print (large bag #1)
- 1-5/8 yards of striped pear/apple print (large bag#2 )
- 1-1/2 yards of a strawberry print (small bag)
- 1 yard of a black dot (straps and edge for all 3 bags)
- 1-7/8 yards of backing fabric for EACH large bag
- 1-5/8 yards of backing fabric for small Bag
- 5-1/2 yards of 45" wide batting (for insulated bags, use the Warm Company InsulBrite)

**Helpful Hint:** To make the bags even faster, use pre-quilted yardage.

## PREPARATION

For each bag, layer the print yardage for the bag front with batting and backing fabric and quilt as desired.

## Cutting Directions:

### LARGE BAG CUTTING FROM QUILTED FABRIC

(Refer to the Cutting Diagram)

- (2) 16-1/2" x 20-1/2" pieces (for each bag)
- (1) 6" x 52-1/2" piece (for each bag)

### LARGE BAG CUTTING LAYOUT DIAGRAM

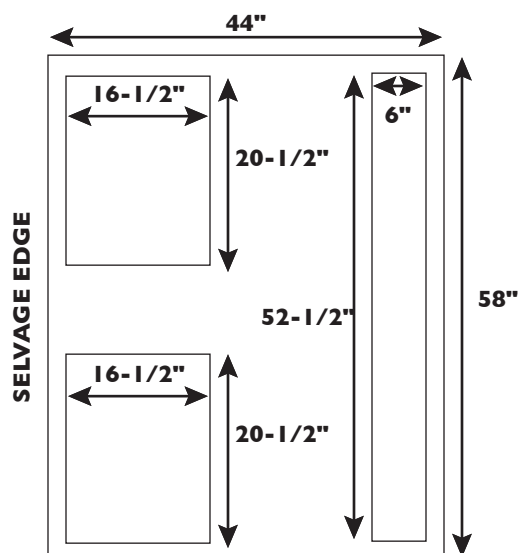

## SMALL BAG CUTTING FROM QUILTED FABRIC

(2) 16-1/2" square pieces

(1) 6" x 48-1/2" piece

## BLACK DOT

(3) 2-1/4" x 42" strips for binding

(12) 2" x 31" strips

## DOUBLE-SIDED FUSIBLE INTERFACING

(6) 1-1/2" x 30" strips

## SMALL BAG CUTTING LAYOUT DIAGRAM

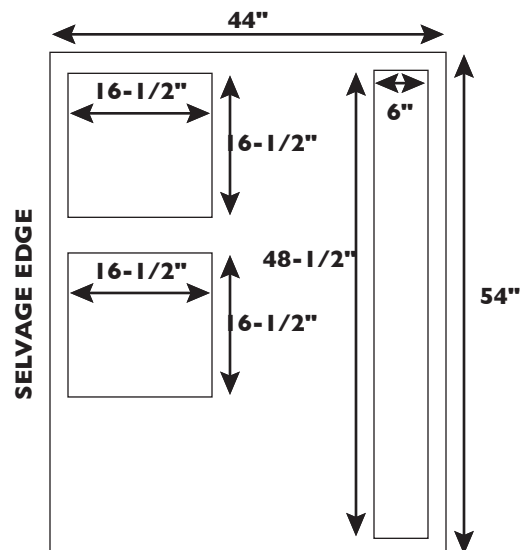

## Sewing Directions: *(Seam allowance is 1/4" unless stated otherwise)*

### Making the Large Bag

1. Pin the 6" x 52-1/2" piece to the sides and bottom of a 20-1/2" x 16-1/2" piece, right sides together. Stitch the pieces together, pivoting as necessary at the corners.

2. In the same manner, sew the other 20-1/2" x 16-1/2" piece to the opposite side of the long 6" x 52-1/2" piece. *Note: For finished seams, sew the bag pieces together using a serger, or overcast the raw edges using a utility stitch on your sewing machine.*

3. Following the manufacturer's instructions, fuse a 1-1/2" x 30" piece of fusible interfacing to the wrong side of a 2" x 31" black dot strip. Repeat to make a total of (4) units. Remove the paper from the fusible webbing and press 1/4" along each long side of each black strip to the wrong side of the strap unit. Fuse (2) strap units together, wrong sides facing, and matching up outer edges. Stitch along each long edge using matching thread.

4. Pin the straps in place 5" in from the side seams on the bag front. Repeat for the bag back.

5. Sew the (3) 2-1/4" x 42" black dot strips short ends together into a long strip. Fold in half lengthwise, wrong sides together, to create a binding. Stitch the binding to the top of the bag, matching raw edges and stitching through the straps. Reserve remaining binding for the second large bag and the small bag. Turn the binding to the inside of the bag and stitch in place by hand or machine.

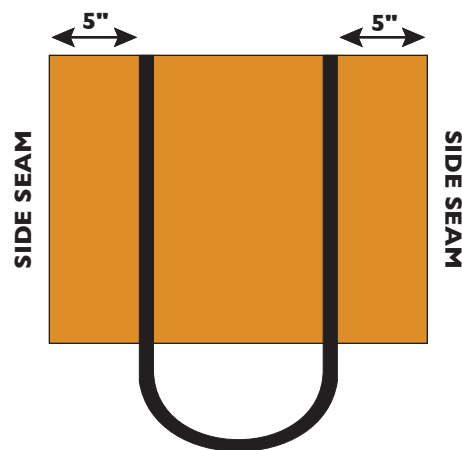

# Making the Small Bag

1. Pin the 6" x 48-1/2" piece to the sides and bottom of a 16-1/2" square piece, right sides together. Stitch the pieces together, pivoting as necessary at the corners.

2. In the same manner, sew the other 16-1/2" square piece to the opposite side of the long 6" x 48-1/2" piece. *Note: For finished seams, sew the bag pieces together using a serger, or overcast the raw edges using a utility stitch on your sewing machine.*

3. Following the manufacturer's instructions, fuse a 1-1/2" x 30" piece of fusible interfacing to the wrong side of a 2" x 31" black dot strip. Repeat to make a total of (4) units. Remove the paper from the fusible webbing and press 1/4" along each long side of each black strip to the wrong side of the strap unit. Fuse (2) strap units together, wrong sides facing, and matching up outer edges. Stitch along each long edge using matching thread.

4. Pin the straps in place 5" in from the side seams on the bag front. Repeat for the bag back.

5. Stitch the binding to the top of the bag matching raw edges and stitching through the straps. Turn the binding to the inside of the bag and stitch in place by hand or machine.

